

# HAW – High Efficiency Water Separator

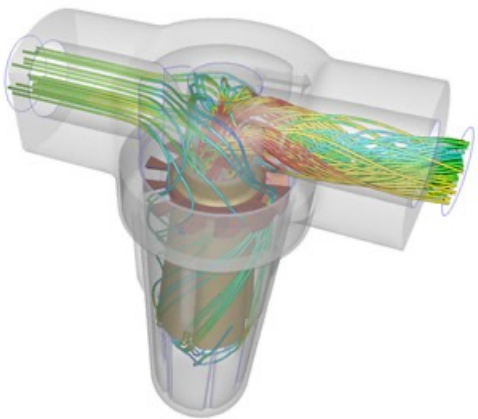

## PRODUCT FEATURES

- 99% efficiency
- Cost-saving
- Easy maintenance, element is unnecessary
- Patent product proved by practice
- High flow capacity
- Low pressure differences
- Equipped with the automatic drainage

(Temperature Range : 1.5°C-100°C  
 Max. Pressure for screw type : 16 bar  
 Max. Pressure for flange type : 10 bar)

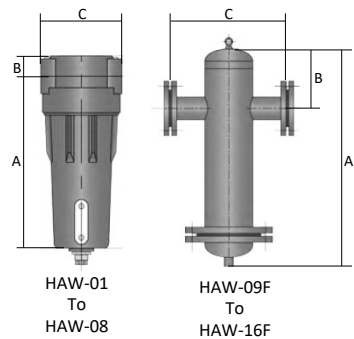

## TECHNICAL SPECIFICATION

Filter	Flow-Rate		Connections IN-OUT (Φ)	Weight (+kg)	Dimension(mm)		
	(l/min)	(scfm)			A	B	C
HAW-01	1,700	60	G 1/2"	1.2	217.00	26.00	104.00
HAW-02	3,500	124	G 1"	1.5	287.00	26.00	104.00
HAW-03	7,100	251	G 1.1/2"	3.0	385.00	39.00	138.00
HAW-04	10,600	374	G 1.1/2"	3.6	585.00	39.00	138.00
HAW-05	13,800	487	G 2"	9.5	639.00	46.00	148.00
HAW-06	17,500	618	G 2"	11.8	779.00	46.00	148.00
HAW-07	22,100	780	G 2.1/2"	12.0	800.00	50.00	150.00
HAW-08	26,000	918	G 2.1/2"	13.6	1,000.00	50.00	150.00
HAW-09F	42,000	1,483	DN65	30.0	713.00	195.00	380.00
HAW-10F	50,000	1,766	DN80	31.0	713.00	195.00	380.00
HAW-11F	60,000	2,119	DN100	92.0	913.00	230.00	449.00
HAW-12F	80,000	2,825	DN125	145.0	1,141.00	263.00	493.00
HAW-13F	120,000	4,238	DN150	160.0	1,210.00	301.00	545.00
HAW-14F	180,000	6,357	DN200	348.0	1,423.00	361.00	750.00
HAW-15F	288,000	10,171	DN250	510.0	1,250.00	410.00	845.00
HAW-16F	432,000	15,256	DN300	662.0	1,269.00	485.00	1,000.00

## MODEL CORRECTION

Pressure(Mpa (g))	0.1	0.3	0.5	0.7	0.9	1.1	1.3	1.5	1.6	2
Correction Factor	0.38	0.65	0.85	1	1.13	1.25	1.36	1.46	1.51	1.62

## ACCESSORY



Ananta Group Trading Ltd.,Part.  
 Email: anantagrouptrading@gmail.com  
 Hot Line : 081-172-1566, 065-056-2564